

Radial piston pumps

Type BRK11/12

heavy duty series

1000 bar

0,47 up to 8,14 cm³/rev

500 bar → see data sheet BRK501/502

700 bar → see data sheet BRK701/702

Features

- High volumetric efficiency
- Self-priming and venting
- Low pulsation
- Low noise level
- Combination with gear pump possible (see separate data sheet BKP)



Design

- Radial piston pump of modular design
- With valve controlled pump elements
- Can be supplied with 3, 5, 7 and 9 pistons per section (depending on size)

Applications

- Specially designed for demanding applications with continuous pressures up to 1000 bar → long economic lifetime!
- Clamping device
- Power units (e.g. for presses)
- Test stands
- Accumulator loading systems
- Lifting and advancing systems

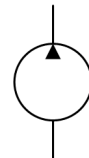

Technical data

Hydraulic fluid	Mineral oil according to DIN 51524 (other fluids on request)	
Fluid temperature range	-20 to 80 °C	
Ambient temperature range	-30 to 50 °C	
Viscosity range	5 to 220 mm ² /s	
Max. operating pressure	1000 bar continuous pressure (S1)	
Operation pressure at suction port	-0,2 bar to 0,5 bar gauge pressure	
Filtration (recommendation)	According to NAS 1638 class 6 resp. ISO/DIN 4406 17/15/12	
Weight	See product information	
Axial force onto driving shaft	Not allowed	
Radial force onto driving shaft	On request	
Max. speed range	2000 min ⁻¹	
Direction of rotation	Any	
Suction height	Max. 500 mm	
Material	Pressure flange:	steel
	Driving shaft:	steel
	Cover:	die casted aluminium

Type BRK11/12

heavy duty series
1000 bar
0,47 up to 8,14 cm³/rev

Ordering code

Example	BRK 11 - 0,47 - 1000 - V - - - 00
Radial piston pump	
Size	11 12
Displacement [cm³/rev]	see product inform.
Max. operating pressure [bar]	see product information
Seal material	V [FPM] other seal materials on request
	Special design 01 ... 99 (00 for standard)
	Part index Please leave it blank (small letters a-z; different letters do not effect interchangeability)
	Design revision see dimension drawings (capital letters A-Z; identical letters equal same connecting dimensions)

Mounting

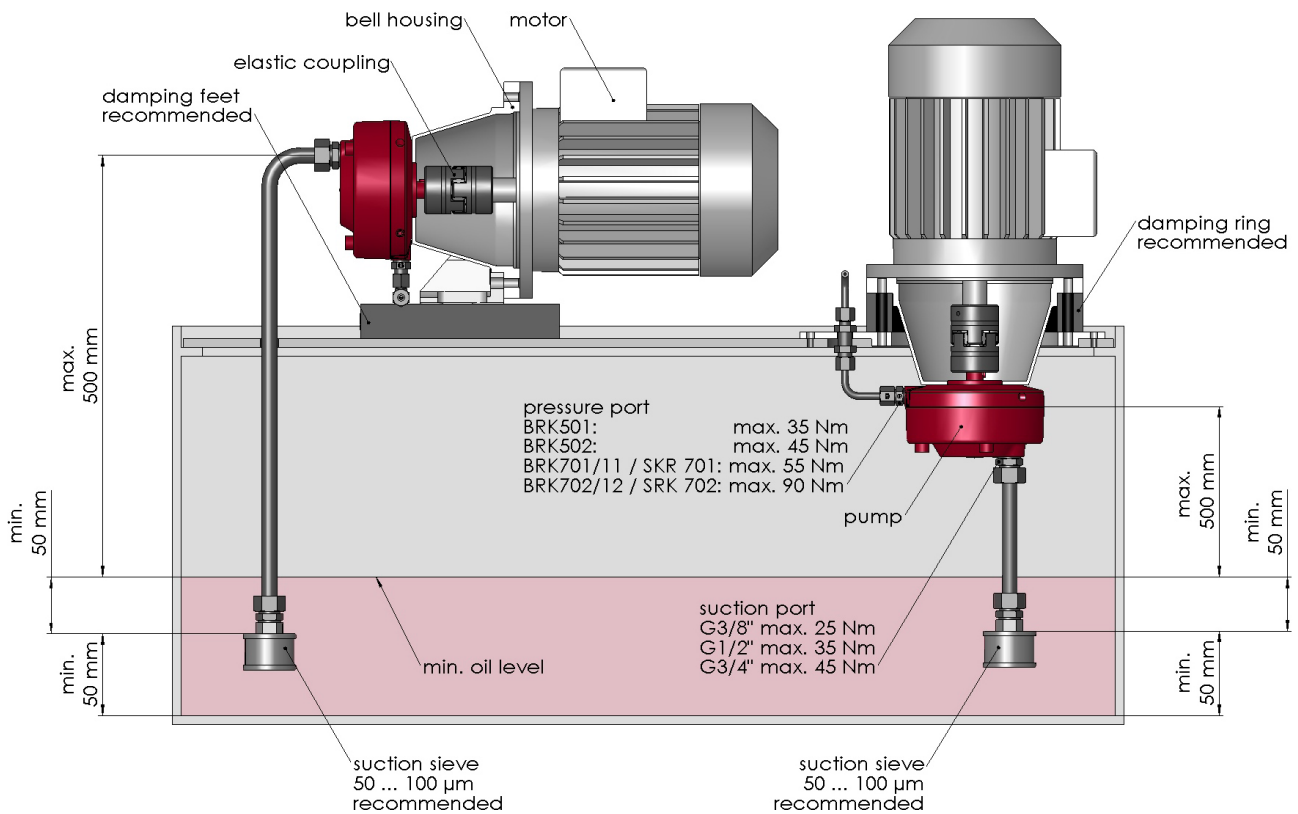

Product information

Size	Displacement [cm ³ /rev]	Operating pressure max. [bar]	Number of pumping elements	Weight ca. [kg]	max. Torque * [Nm]	max. Power * [kW]	Part No.
11	0,47	1000	3	7,0	9,84	1,55	3675409
11	0,68	1000	3	7,0	14,18	2,23	3675413
11	1,13	1000	5	7,5	22,95	3,60	3675442
11	1,21	1000	3	7,0	25,20	3,96	3675448
11	1,53	1000	3	7,0	31,89	5,01	3675454
11	1,88	900	3	7,0	35,44	5,57	3675467
11	2,01	1000	5	7,5	40,80	6,41	3675470
11	2,54	900	5	7,5	46,47	7,30	3677017
11	2,71	850	3	7,0	48,20	7,57	3677035
12	1,10	1000	7	12,5	22,09	3,47	3677088
12	1,58	1000	7	12,5	31,82	5,00	3677091
12	2,81	1000	7	12,5	56,56	8,88	3677094
12	3,56	1000	7	12,5	71,58	11,24	3677097
12	4,40	900	7	12,5	79,54	12,49	3677100

* n = 1500 1/min; $\eta_t = 0,8$; p = p_{max}

Calculation of driving motor power

$$P = \frac{p \cdot V_g \cdot n \cdot k}{\eta_t \cdot 600 \cdot 10^3}$$

P = Driving power [kW]
 p = Operating pressure [bar]
 V_g = Displacement [cm³/rev]
 n = Speed [rpm]
 η_t = Overall efficiency approx. 0,8

k = Pulsation factor
 - with 3 pumping elements: k approx. 1,05
 - with 5 pumping elements: k approx. 1,02
 - with 7 pumping elements: k approx. 1,01
 - with 9 pumping elements: k approx. 1,00

Sealkit for BRK11	4006555
-------------------	---------

Sealkit for BRK12	4006557
-------------------	---------

Type BRK11/12

heavy duty series
1000 bar
0,47 up to 8,14 cm³/rev

Dimensional drawings

Size BRK11 / Design revision B

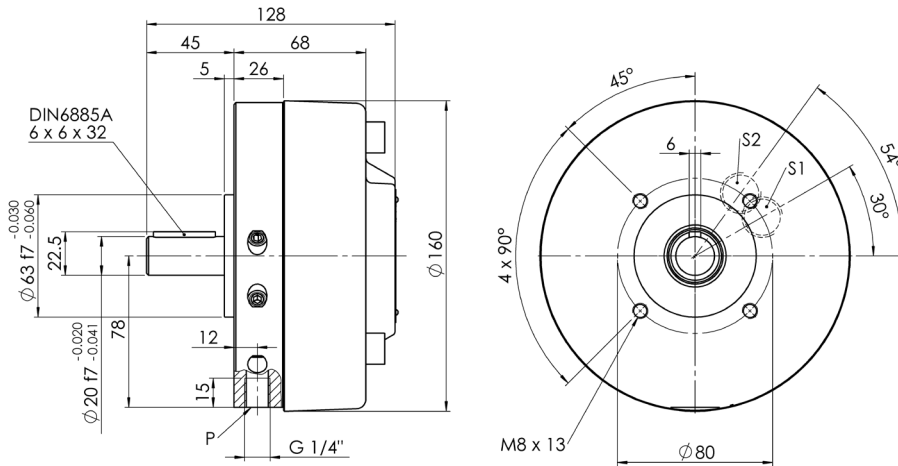

Suction connection

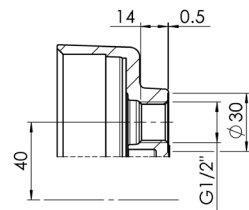

S1: 3 pumping elements
S2: 5 pumping elements

Size BRK12 / Design revision B

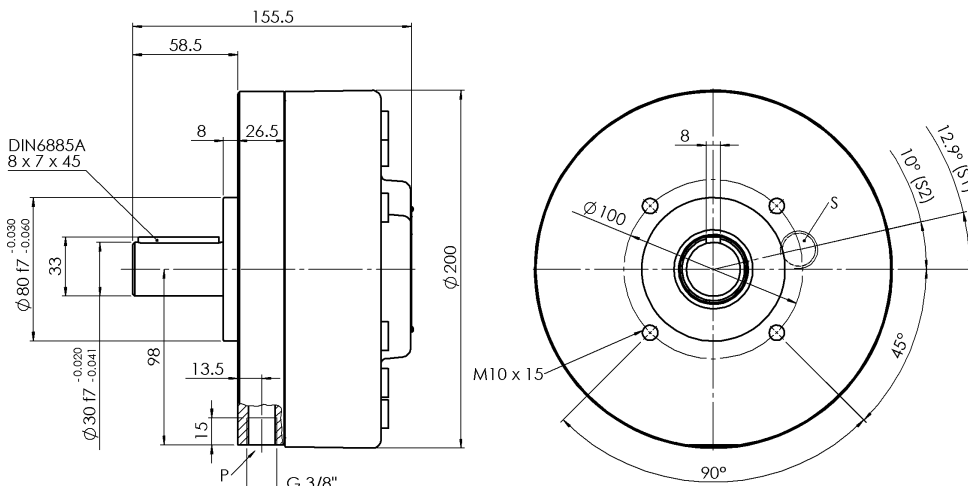

Suction connection

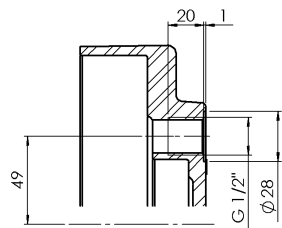

S1: 7 pumping elements
S2: 9 pumping elements

Bieri Hydraulik AG

Könizstrasse 274
CH-3097 Liebefeld
Tel. +41 31 970 09 09 | Fax +41 31 970 09 10
info@bierihydraulics.com | www.bierihydraulics.com
4/4

The information in this brochure relates to the operating conditions and applications described.
For applications and operating conditions not described, please contact the relevant technical department.
Subject to technical modifications.

BRK11-12_1802